



CAG 18-125 Li

1

**TSSP**  
ПРЕВЫШАЯ СТАНДАРТЫ





:

- 1.
- 2.
- 3.
- 4.
- 5.
- 6.

1.

1.1

•

•

•

•

•

•

•

•

•

1.2

•

•

•

•

•

•

•

•

1.3

•

•

•

•

• ) ( -

• -

• -

• -

• -

• -

1.5 -





1. ( )



1. ( )



1

( ) ( ).

-

,

-

2.

-

( , ) -

,

,

-

-

-

-

2



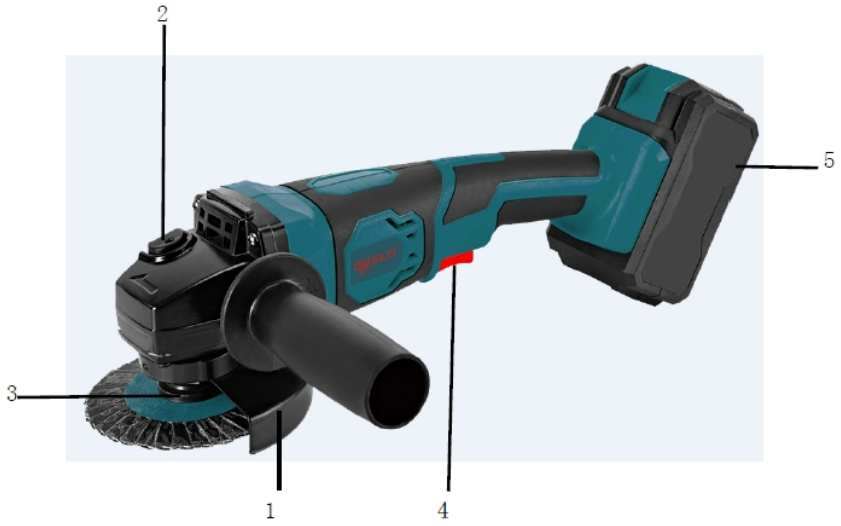

- 2.
- 1.
  - 2.
  - 3.
  - 4.
  - 5.
- 18

:

-

-

-



3.

	CAG 18-125 Li
	18
, Ah	3
, /	11000
	125
	14
	II
	IP X0

4.

/ ! , 80

4.1

•

3.

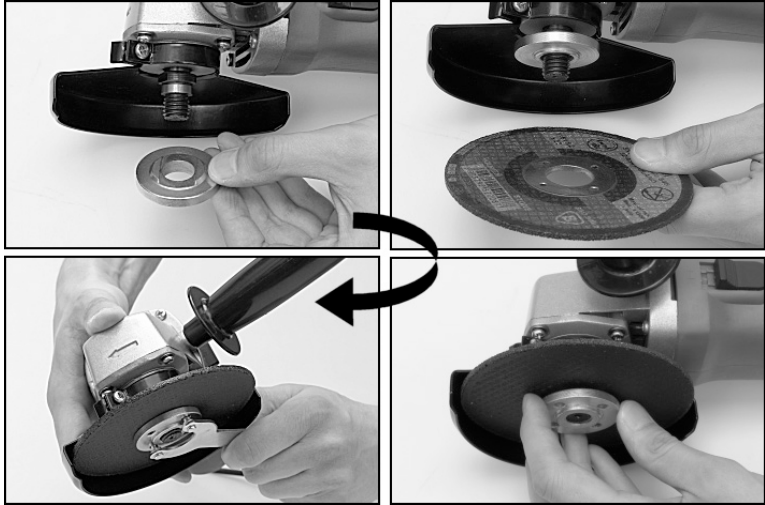

3.



!

3,2 )

(

3,2 ),

4.

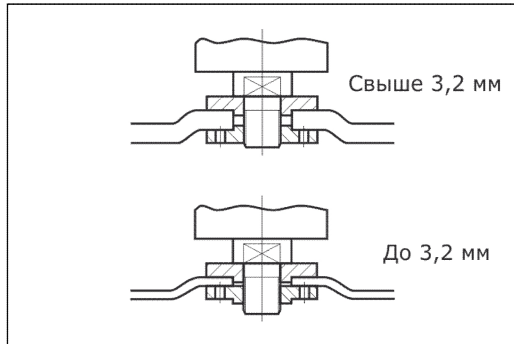

4.



•

4.2

•

•

•

•

•

•

•

•	/	-
•	/	-
• «	»..	-
•	/	-
	/	-
	/	-
•	/	-
•	/	-
	/	-
	/	-
-	/	-
-	/	-
-	/	-

-

-

- 
- 30 (
- 1 ).
- 
- 

-

-

-

-

-

-

-

-

- 
- ( 1 ).
- 
- 
- 
- 60 .
- 
- 
- !



5.



- 
- 
- 
- 
- 
- 
- 

0,3 MPa),

- 
- 
- 

5 ),





6.

5.1

-

12

5.2

-

-

-

5.3

-

.

:

-

-

;

-

-

;

-

;

-

5.4

-

.





8 (7172) 55-44-40 , 8/1

8 (727) 311-77-00 , 157

8 (7252) 99-77-11 111

8 (7122) 55 66 00 , 45

**КОНТАКТ ЦЕНТРЫ**

АСТАНА	8 (7172) 55 44 40
АЛМАТЫ	8 (727) 331 77 00
ШЫМКЕНТ	8 (7252) 99 77 11
АТЫРАУ	8 (7122) 55 66 00

[www.tssp.kz](http://www.tssp.kz)

**TSSP**

ПРЕВЫШАЯ СТАНДАРТЫ

